



**EUROMAG**  
INTERNATIONAL

*Measure > Sense > Innovate*

# SENSOR MUT1000EL

Electromagnetic flowmeter



*The wafer electromagnetic flowmeter*



DS120-2-ENG



## Sensor MUT1000EL

MUT1000EL sensors represent the state of the art of Euromag International production for water cycle and process applications. The new structure for the generation of the magnetic field and the innovative route of the signal generated by the electrodes, provide a sensor with an extremely wide measurement range:

EL= Extended Linearity

This new sensors series follows the successful tradition of the MUT1000EL, introducing a measurement range of more than 1:1000 without linearization software. These kinds of performances allow very accurate measures on a wide flowrate range and to count lower flow rates that, before, would have been reset because of the effect of the converters cut off.

This flanged sensors series bases its operation on the Faraday Principle, by which a conductor crossing a magnetic field generates a potential perpendicularly orientated to the same field.

In this case the flow tube made in stainless steel AISI 304 is equipped with carbon steel or stainless steel flanges, two coils are installed on the top and inferior part; the magnetic field, generated by the electric current crossing the coil, induces in the electrodes a difference in the potential proportional to the flow rate.

With the aim of measuring such potential of very low values, the interior of the flow tube is electrically insulated, thus the process liquid is no longer in contact neither with the material of the flow tube nor with that of the flange.

The converter used generates the current supplying the coil, acquires the electrodes difference of potential, process the signal to calculate the flowrate and administers the communication with the exterior.

The entire sensor, when installed in the separate version, has a degree of protection IP68 suitable for a permanent immersion in water up to a depth of 1.5m thanks to a welded plate structure containing the coil and the electrodes.

## Body and connection

MUT1000EL SENSORS have the flow tube made in stainless steel AISI 304 and the structure is made in acrylic painted carbon steel. This treatment gives the sensor an excellent resistance to water, even in permanent immersion. It is equipped with a junction box to connect the cables to the converter. Its standard degree of protection is IP68, suitable for a permanent immersion in water at 1,5m. It is installed between flanges UNI 2223 from PN 16 to PN 40 or between flanges ANSI 150, 300.



## Internal lining

The standard internal insulating lining is in PTFE for diameters from DN25 to DN100, in hard rubber for food stuff (ebonite for food) for diameters of more than DN100. On request the sensors may be supplied coated with PTFE for diameters of more than DN100. The temperature of the liquid to be measured is limited by the type of internal lining used.

## Electrodes and grounding

The standard electrodes are in Hastelloy C and, therefore, guarantee a wide compatibility with the process liquids, if required they may be supplied in other materials. A grounding electrode and an empty pipe electrode are also provided to monitor conditions of partly filled pipe.

## Coupling and sensor connection

MUT1000EL sensors may be coupled with any Euromag converters. In the separate version the sensor is connected to the converter by means of cables whose length depends on the liquid conductivity; the maximum length shall not exceed 100 metres (30 meters in combination with battery operated electronics).

## Calibration and maximum error

MUT1000EL sensors belong to the reference Group B1 (ISO 11631). Each sensor is calibrated on an hydraulic bench equipped with a reference weighting system and SIT certified. The uncertainty of the calibration is equal to 0.2% +/- 2 mm/s. The repeatability is in the order of 0.1%.

## Reference standards

The Euromag magnetic meters are marked CE and are manufactured according to the following standards:

- 2014/35/EU - EN 61010-1:2013 (LVD)
- 2014/30/EU - EN 61326-1:2013 (EMC)
- 2014/34/UE - IEC 60079 - 0, IEC 60079 - 18 (ATEX - IECEx) Separate version
- EN ISO 15609-1 and EN ISO 15614-1
- UNI EN ISO 12944-2, painting for C4 class environments (on request)
- PTFE conform to the norms WRAS, FDA, DPR 777/82 e DM 21/09/773
- Ebonite conform to the norms WRAS, FDA e DM174



## Available electrodes

* Hastelloy C (standard)	* Titanium
* Hastelloy B	* Tantalum
	* Platinum

## General characteristics of MUT1000EL sensors

<b>Available diameters[mm]</b>	25 mm 1"	40 mm 1.1/2"	50 mm 2"	65 mm 2.1/2"	80 mm 3"	100 mm 4"	125 mm 5"	150 mm 6"	200 mm 8"	250 mm 10"	300 mm 12"
<b>Joints: coupling flanges</b>	EN1092-1, ANSI 150, ANSI 300, ANSI 600, ANSI 900, DIN 2501, BS 4504, AS 2129 (TABLE D - E - F), AS 4087, ISO 7005-1, KS 10K										
<b>Maximum pressure</b>	40 bar for diameters < DN150						16 bar for diameters > DN200				
<b>Internal lining and liquid temperature [1]</b>	<b>Internal lining</b>						<b>Liquid temperature</b>				
	PTFE						Standard -40 /+130°C (up to +180° on request)				
	Ebonite						-40°C / +80°C				
<b>Degree of protection</b>	IP68 continuous immersion at a 1,5 m (EN 60529)										
<b>Compatible converters</b>	MC608 A/B/R/P/I, MC406										
<b>Electric connections</b>	Cable glands M20 x 1.5 + terminal block + sealing resin										

[1] Compact version Tmax 80°C.

## Weight of MUT1000EL sensors in the separate version without package

<b>DN</b>	[mm]	25	40	50	65	80	100	125	150	200	250	300
<b>DN</b>	[ " ]	1"	1" 1/2	2"	2" 1/2	3"	4"	5"	6"	8"	10"	12"
<b>WEIGHT</b>	[kg]	2,1	2,5	3,0	4,5	6,5	7,5	9,5	11,5	17	21	26

## MUT1000EL

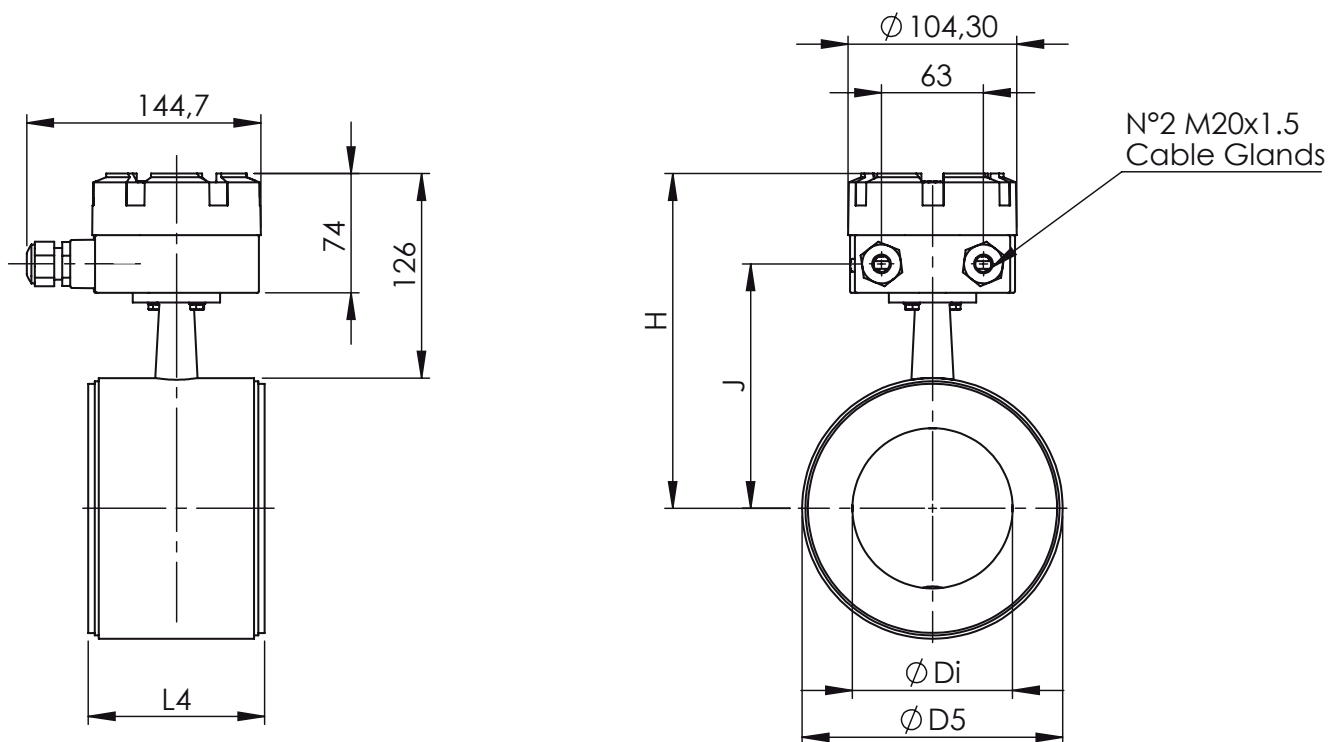

DN	L4	Di	D5	H	J
25	86	24	74	163	108
32	87	32	83	168	112
40	87	35	88	170	115
50	87	47	102	177	122
65	96	63	114	183	128
80	90	75	127	190	134
100	109	99	161	207	151
125	110	124	186	219	164
150	130	152	216	234	179
200	169	201	267	260	204
250	169	255	319	286	230
300	195	308	371	312	256

**MUT1000EL - MC608A/B/R**

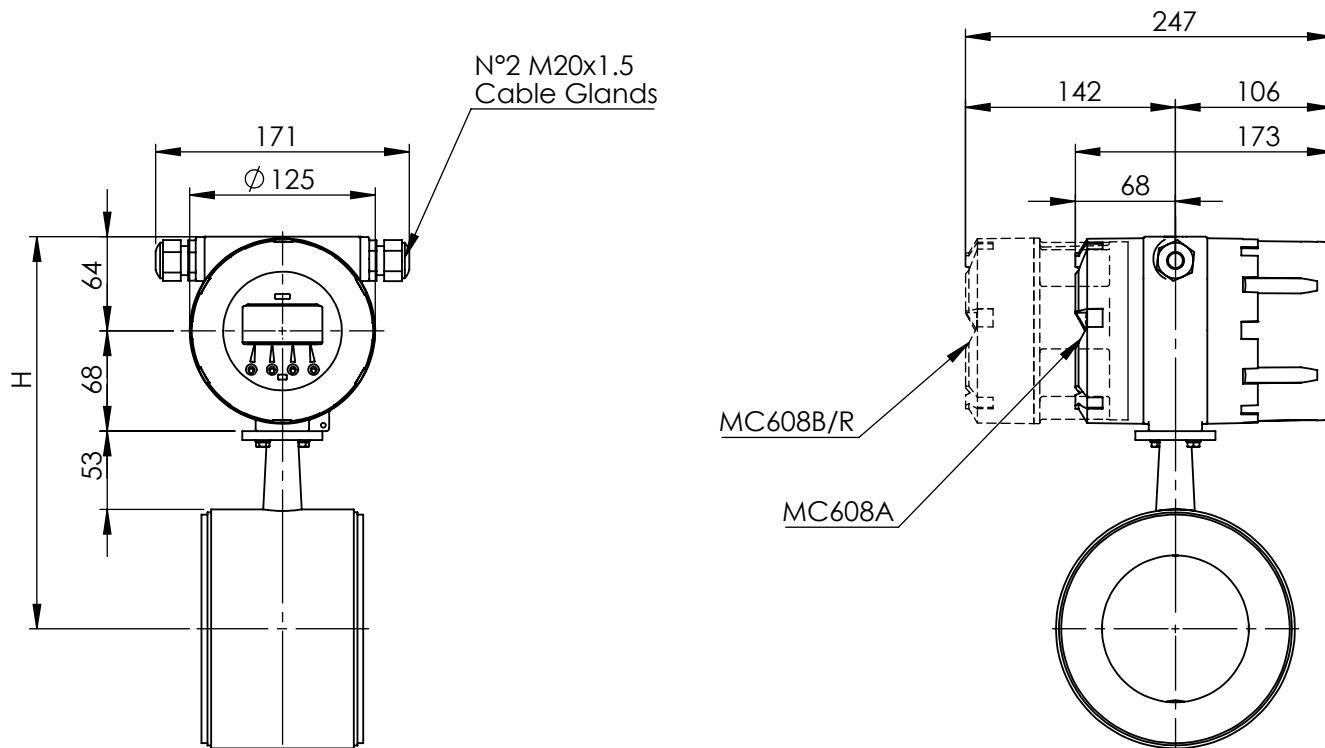

DN	H
25	222
32	227
40	229
50	236
65	242
80	249
100	266
125	278
150	293
200	319
250	345
300	371

### MUT1000EL - MC406 VERTICAL

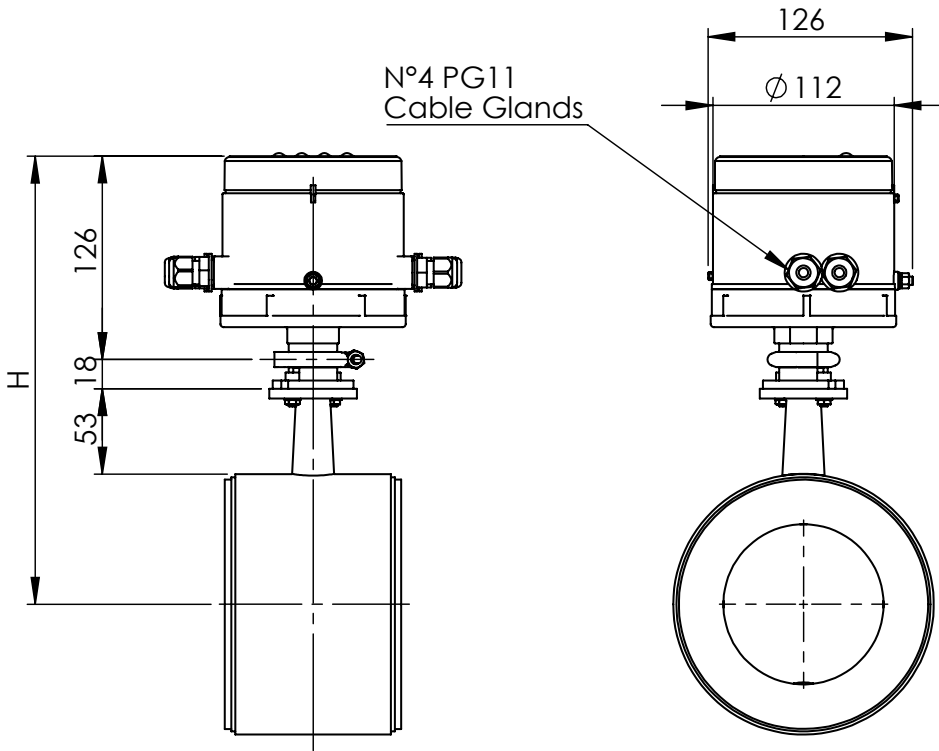

DN	H
25	234
32	239
40	241
50	248
65	254
80	261
100	278
125	290
150	305
200	331
250	357
300	383

### MUT1000EL - MC406 HORIZONTAL

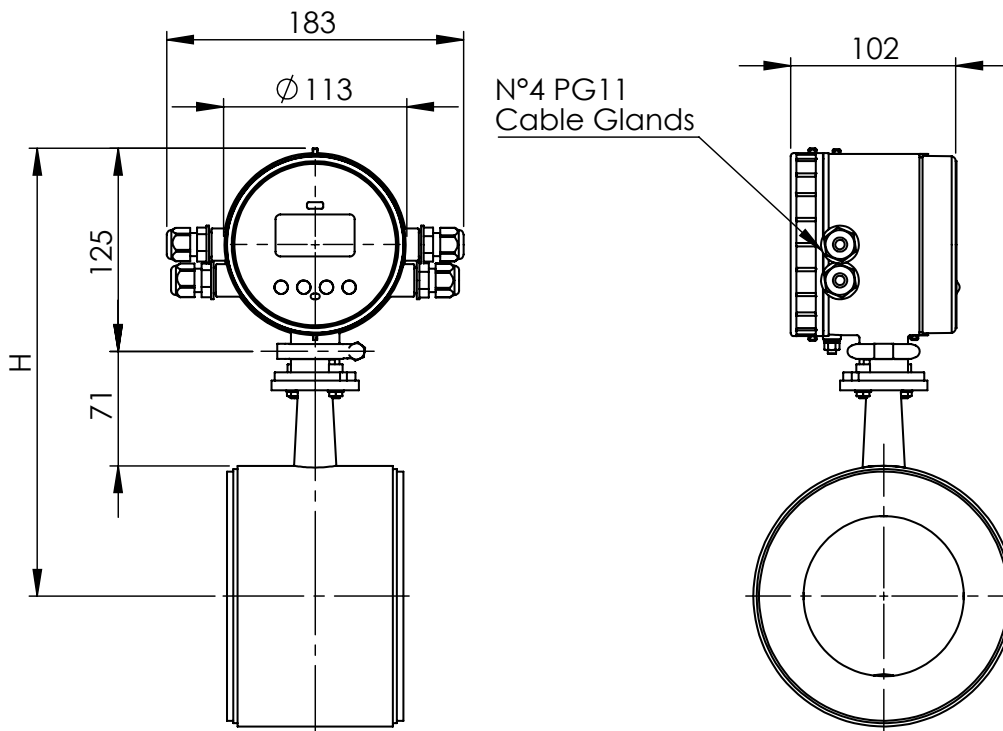

DN	H
25	233
32	238
40	240
50	247
65	253
80	260
100	277
125	289
150	304
200	330
250	356
300	382



*Measure > Sense > Innovate*



**EUROMAG**  
INTERNATIONAL

*Measure > Sense > Innovate*



**EUROMAG INTERNATIONAL Srl**

Via della Tecnica, 20 - 35035 Mestrino (Padova) Italia  
Tel. +39 049.9005064 - Fax +39 049.9007764

[www.euromag.com](http://www.euromag.com) - [www.euromagdata.com](http://www.euromagdata.com)  
[euromag@euromag.com](mailto:euromag@euromag.com)